

SECTION A-A WITH TYPE II CURB AND GUTTER

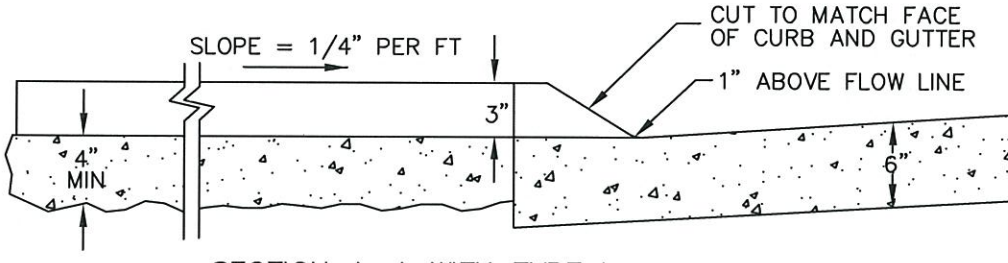

SECTION A-A WITH TYPE I CURB AND GUTTER

NOTES:

1. MATERIAL
 - A. BOX - 1/4" A36 STEEL PLATE.
 - B. LID - 1/4" A36 STEEL TREAD PLATE, BOLTED TO ANGLE WITH MIN. 4 - 1/4" FLAT HEAD BOLTS.
 - C. REBAR - #4, GRADE 40, WELDED TO BOX WITH 1/4" FILLET WELD ALL AROUND.
 - D. ANGLE - 1-1/4" X 1-1/4" X 1/4" A36 STEEL WELDED TO BOX 1/8" FILLET WELD 2" LONG ON 6" CENTERS.
 - E. CONCRETE - TO MEET CITY OF LARAMIE STANDARD SPECIFICATIONS.
 - F. SIDEWALK TO BE WIDENED 1' AT BACK OF WALK IF THERE IS A TRENCH

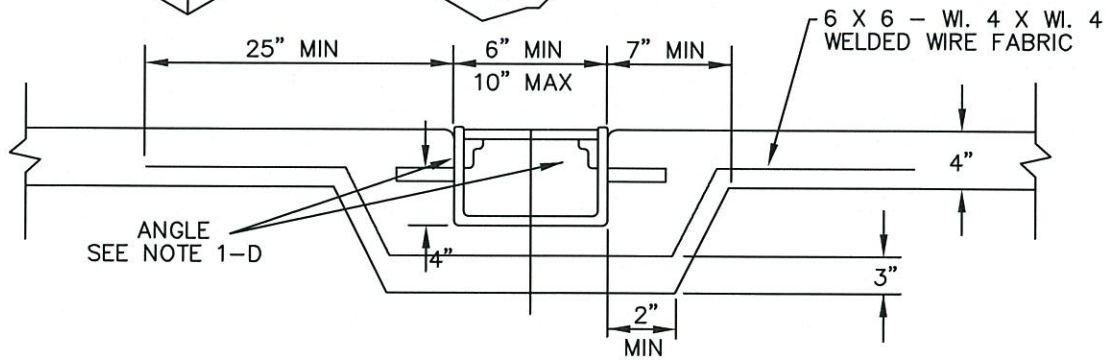
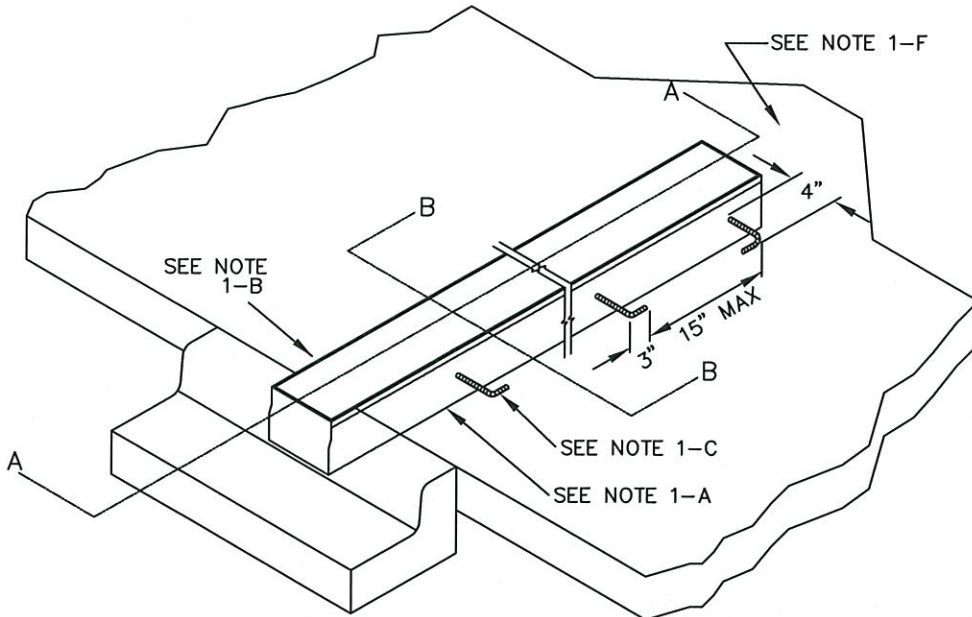

SECTION B-B END VIEW